



SMD Shielded Power Chokes - SDS74 SERIES



PART NUMBERING SYSTEM

(AEC-Q200)

SDS	74	—	471M	—	LF
TYPE	DIMENSIONS		INDUCTANCE		LEAD FREE

SHAPES AND DIMENSIONS

UNIT : mm

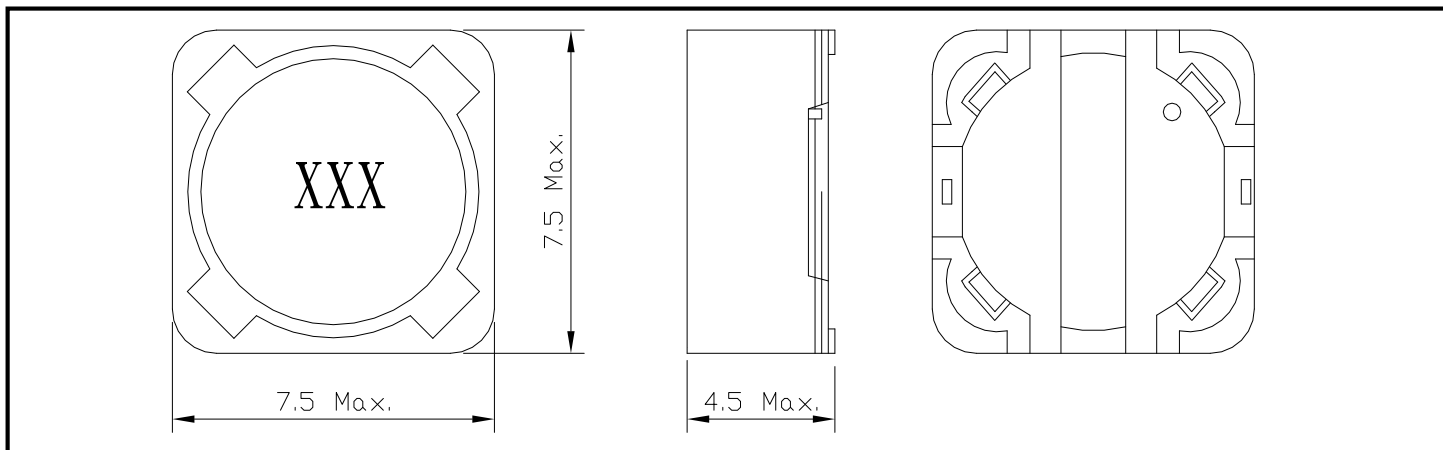

PACKAGING SPECIFICATION

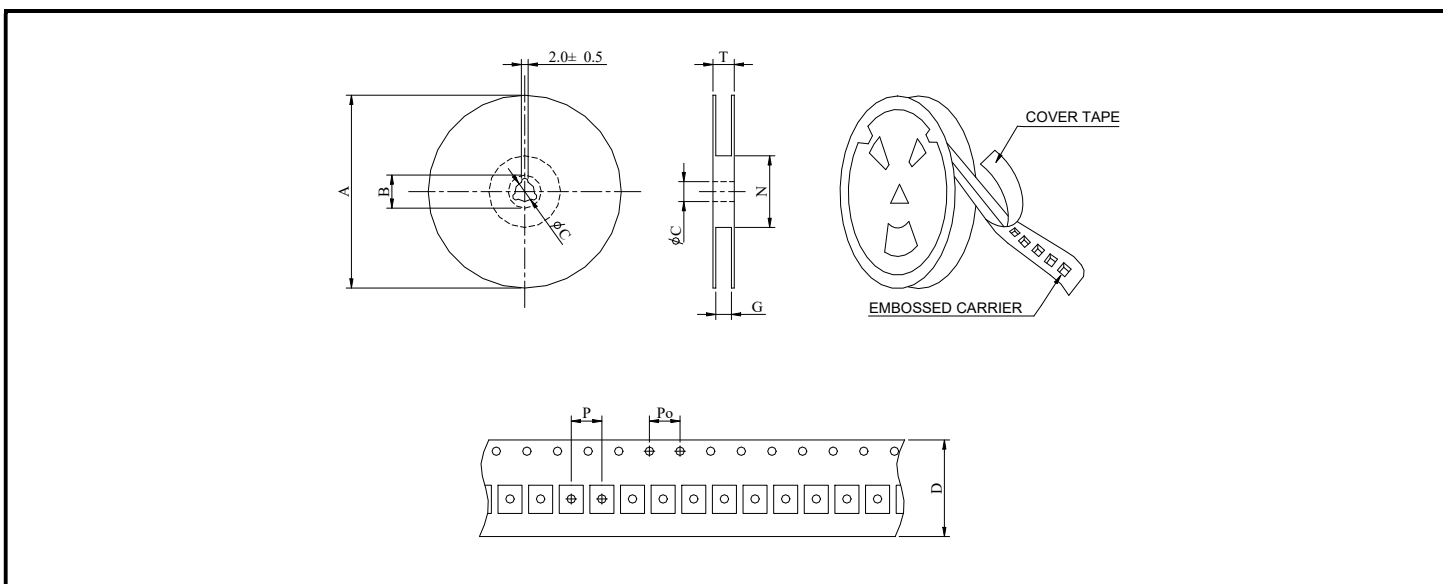

SERIES	STAYLE	Q' TY (PCS)	DIMENSIONS (m/m)								
			A	B±0.8	C±0.5	D	G ⁺⁰	N ⁰	P	Po	T
SDS74	13-16	1000	330	21	13	16	18	50	8	4	22.4



SMD Shielded Power Chokes - SDS74 SERIES



SPECIFICATION TABLE

(AEC-Q200)

PART NUMBER	INDUCTANCE (μ H)	DCR (Ω) (Max.)	IDC (A) (Max.)	TEST FREQ. (Freq.)
SDS74-100M-LF	10 \pm 20%	0.049	1.84	1KHz
SDS74-120M-LF	12 \pm 20%	0.058	1.71	1KHz
SDS74-150M-LF	15 \pm 20%	0.081	1.47	1KHz
SDS74-180M-LF	18 \pm 20%	0.091	1.31	1KHz
SDS74-220M-LF	22 \pm 20%	0.110	1.23	1KHz
SDS74-270M-LF	27 \pm 20%	0.150	1.12	1KHz
SDS74-330M-LF	33 \pm 20%	0.170	0.96	1KHz
SDS74-390M-LF	39 \pm 20%	0.230	0.91	1KHz
SDS74-470M-LF	47 \pm 20%	0.260	0.88	1KHz
SDS74-560M-LF	56 \pm 20%	0.350	0.75	1KHz
SDS74-680M-LF	68 \pm 20%	0.380	0.69	1KHz
SDS74-820M-LF	82 \pm 20%	0.430	0.61	1KHz
SDS74-101M-LF	100 \pm 20%	0.610	0.60	1KHz
SDS74-121M-LF	120 \pm 20%	0.660	0.52	1KHz
SDS74-151M-LF	150 \pm 20%	0.880	0.46	1KHz
SDS74-181M-LF	180 \pm 20%	0.980	0.42	1KHz
SDS74-221M-LF	220 \pm 20%	1.170	0.36	1KHz
SDS74-271M-LF	270 \pm 20%	1.640	0.34	1KHz
SDS74-331M-LF	330 \pm 20%	1.860	0.32	1KHz
SDS74-391M-LF	390 \pm 20%	2.850	0.29	1KHz
SDS74-471M-LF	470 \pm 20%	3.010	0.26	1KHz
SDS74-561M-LF	560 \pm 20%	3.620	0.23	1KHz
SDS74-681M-LF	680 \pm 20%	4.630	0.22	1KHz
SDS74-821M-LF	820 \pm 20%	5.200	0.20	1KHz
SDS74-102M-LF	1000 \pm 20%	6.000	0.18	1KHz

- DC current at which the inductance drops 25% (typ.) from its value without current.
- Operating temperature range -40°C to +125°C .
- Electrical specifications at 25°C .